



USER MANUAL



PP500, PP520, PP500F, PP520F LED Lighting Controllers

Revision 10 (for serial numbers 320000 onwards)

Gardasoft Vision Ltd
Castle Acres, Elsworth
Cambridge, CB23 4JQ, UK
Tel: +44 1954 200343
Fax: +44 1954 204343
Web: www.gardasoft.com

1 Disclaimer

Except as prohibited by law:

- All hardware, software and documentation is provided on an “as is” basis.
- It is essential that the user ensures that the operation of the product is suitable for their application.
- The user must ensure that incorrect functioning of this equipment cannot cause any dangerous situation or significant financial loss to occur.
- Gardasoft Vision Ltd and Gardasoft Products Ltd will not accept any liability for consequential loss of any kind.

All trademarks acknowledged. Hardware, software and documentation are Copyright 2002 – 2008 Gardasoft Products Ltd. Hardware manufactured by Gardasoft Vision Ltd under licence.

2 Getting Started

Read the sections on Safety and Specifications and check the PP500 fulfils your requirements. See the back cover for other Gardasoft Vision lighting controllers. If you have previously used the PP600 range, see APP920 (at www.gardasoft.com) for differences between the PP600 and PP500.

Connect the PP500 up to a supply and an LED lighting unit as described in Connections. When the PP500 powers up it should show two alternating lines on the display to indicate that it is operating properly.

Users who have a PP520 should refer to the Ethernet Configuration and Ethernet Communications sections.

Mount the PP500 as described in “Mechanical Fixing” using a DIN rail or the mounting holes. Read the section on Heat Dissipation. Set up the PP500 for the desired operation and test.

Visit www.gardasoft.com for more Application Notes. There is also a Support page which has information on troubleshooting problems.

Throughout this manual, references to the PP500 refer to all variants in the PP500 range unless otherwise stated. PP520 also refers to the PP520F. The symbol “us” is used to denote microseconds.

3 Safety - English

3.1.1 PP500 – Safety

Please read this before using the PP500 family of products. If in doubt, contact your distributor or Gardasoft Vision.



Where this symbol appears in the manual, refer to the text for precautions to be taken.

3.1.2 Heat



The PP500 can get very hot. It should be positioned where personnel cannot accidentally touch it and away from flammable materials.

Read the section on Heat Dissipation. Do not exceed the power ratings given in the manual. Note that at the maximum ratings the case temperature can reach 65°C.

3.1.3 Electrical

The user must ensure that the potential difference between any combination of applied signals does not exceed 48V. WARNING: Higher voltages may cause a danger to personal health.

The PP500 does not have complete tracking isolation of inputs and outputs.

Transients caused by inductive loads must be suppressed external to the PP500.

3.1.4 General

The PP500 must not be used in an application where its failure could cause a danger to personal health or damage to other equipment.

If the equipment is used in a manner not specified by the manufacturer, the protection provided by the equipment may be impaired.

4 Mechanical Fixing

The PP500 can be mounted onto a flat surface using the mounting holes in the corners, see diagram. The PP500 should only be mounted either vertically or with its base horizontal. It should be mounted at least 15mm away from the sides of plastic enclosures. Likewise leave a similar space between the PP500 and any parts which could be affected by high temperatures.



The enclosure of the PP500 is used to dissipate power in the form of heat. See the section on Heat Dissipation.

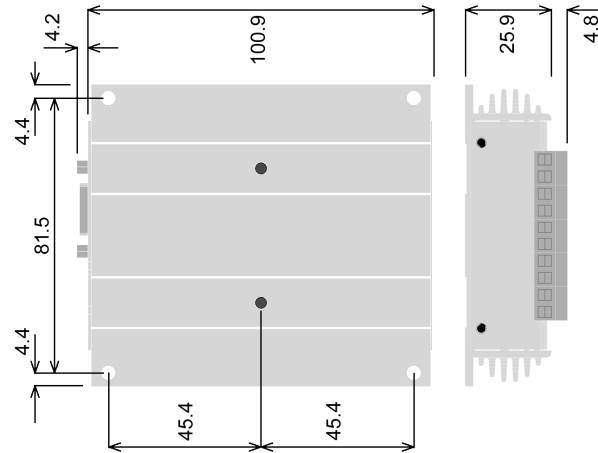

The PP500 can be mounted from above using the M4 clearance corner holes, or from beneath using the M4 tapped holes (maximum screw length inside is 6mm).

The PP701 kit is available for mounting the PP500 on a DIN rail.



To avoid a fire hazard consider the implications of overheating in the unlikely event of a fault in the PP500. The power dissipation in a fault condition is approximately given by the sum of the following for the two channels:

$\langle \text{Power supply voltage} \rangle - \langle \text{rated voltage for lighting} \rangle * \langle \text{max current delivered by Power supply} \rangle$

Either limit the power supply output current(s) so that not more than 30W can be dissipated in the PP500, or mount the unit in an enclosure.

Choose a PSU that limits its output current by design, by setting the current limit on the supply (if this feature exists) or use fuses. Remember to derate the fuse, if mounted in an enclosure, as the temperature will be higher than ambient.

The PP500 enclosure is a fire enclosure as long as the following conditions are met:

- The Ethernet connector must not be facing downwards
- The mounting holes on the underside must be covered or have a screw fitted.

If an enclosure is used, the enclosure should be metal or plastic (with a flammability rating of UL94 V1 or better); with no holes below or to the sides of the PP500 when mounted. Cable entries below the PP500 should be via glands that have a flammability rating as before. Observe the specified gap between the PP500 and any other part or side of the enclosure.

The PP500 does not have an IP rating and should be mounted so that moisture and dirt cannot enter the unit.

5 Heat Dissipation



The PP500 has a linear circuit to produce the constant current output. This means that it generates heat which needs to be dissipated.

5.1.1 Heat Output Per Channel

For a continuous output current the heat output is given by:

$$\langle \text{heat output (W)} \rangle = \langle \text{output current (A)} \rangle * (\langle \text{supply voltage (V)} \rangle - \langle \text{voltage across lighting (V)} \rangle)$$

where:

Output current	Set by the user
Supply voltage	Voltage across PSU+ and PSU-
Voltage across lighting	Voltage across LD1+ and LD1- (for channel 1)

This is usually easy to calculate as the voltage across the lighting is usually the voltage rating of the light given in its specification or can be measured using a voltmeter.

For a pulsed output the heat output is given by:

$$\langle \text{heat output (W)} \rangle = \langle \text{output current (A)} \rangle * \langle \text{duty cycle} \rangle * (\langle \text{supply voltage (V)} \rangle - \langle \text{voltage across lighting when pulsing (V)} \rangle)$$

$$\langle \text{duty cycle} \rangle = \langle \text{pulse width in seconds} \rangle * \langle \text{trigger frequency in Hertz} \rangle$$

When overdriving, the voltage across the lighting is more difficult to find out. In most cases it is reasonable to use the voltage rating of the light.

5.1.2 Total Heat Output

The heat output for the PP500 is given by adding the heat output for both channels, as calculated above.

There are several ways to reduce the heat output from the PP500:

- Use pulse mode. If the output is only on when you need it then you can dramatically reduce the heat output. Feed the camera trigger into the PP500 and pulse the lights.
- Turn the light off when not needed. If you don't have precise timing of when the camera will trigger, you can use Switched mode to switch the output off or on depending on the trigger input (or use the PP520 and use Ethernet commands to turn the output on and off).
- Reduce the output current if possible
- Reduce the supply voltage. Most PSUs have some adjustment in their output voltage.
- Connect lights in series instead of parallel. If you have an array of lights or LEDs in parallel then changing the arrangement to serial will increase the voltage across them but reduce the overall current.
- Use two PP500s and use one channel from each. For high power applications this may be the easiest solution. Even with one light, it is possible to parallel up two output channels from different PP500s.
- Use a PP860. These controllers can dissipate much more heat.

If the heat output is no greater than 8W, then no heatsinking is required. If the heat output is between 8W and 24W then the PP500 needs to be bolted to a solid piece of metal to dissipate the heat. Above 24W, it is necessary to have a large heatsink with fan cooling.

6 Connections

The screw terminals have the following connections:

Opto-Coupled Trigger Input Details

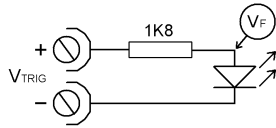

Operating Conditions

$4.5V \leq V_{TRIG} \leq 24V$	Logic 1
$V_{TRIG} < 1V$	Logic 0
V_F	1.5V typ

Screw Terminal ID	Function
TRIG1-	Channel 1 trigger input - see illustration to left
TRIG1+	
LED1+	Channel 1 output to lighting
LED1-	
PSU+	Power Supply +ve
PSU-	Power Supply -ve (GND)
LED2-	Channel 2 output to lighting
LED2+	
TRIG2+	Channel 2 trigger input - see illustration to left
TRIG2-	

Ensure that the wire gauge used for these connections is appropriate for the current to be drawn. Ideally, wires should be double crimped or independently secured to ensure they cannot come loose. Route low voltage and mains wiring separately. If they must be loomed together ensure that low voltage insulation rating is sufficient or that supplementary insulation is used.

The PP500 has a single power input connection (which is different from the PP600).

Power supplies should be regulated with SELV compliant outputs (fault tolerant). Consideration should be given to fusing PSU+. The fuse value can be based on the average current output. Note that in Europe fuses are designed to conduct at their rated current, while in the USA fuses are designed to blow at their rated current.

The RJ45 Ethernet connector requires a straight through cable to connect into a network switch, hub or router. It runs at 10Mbits per second.

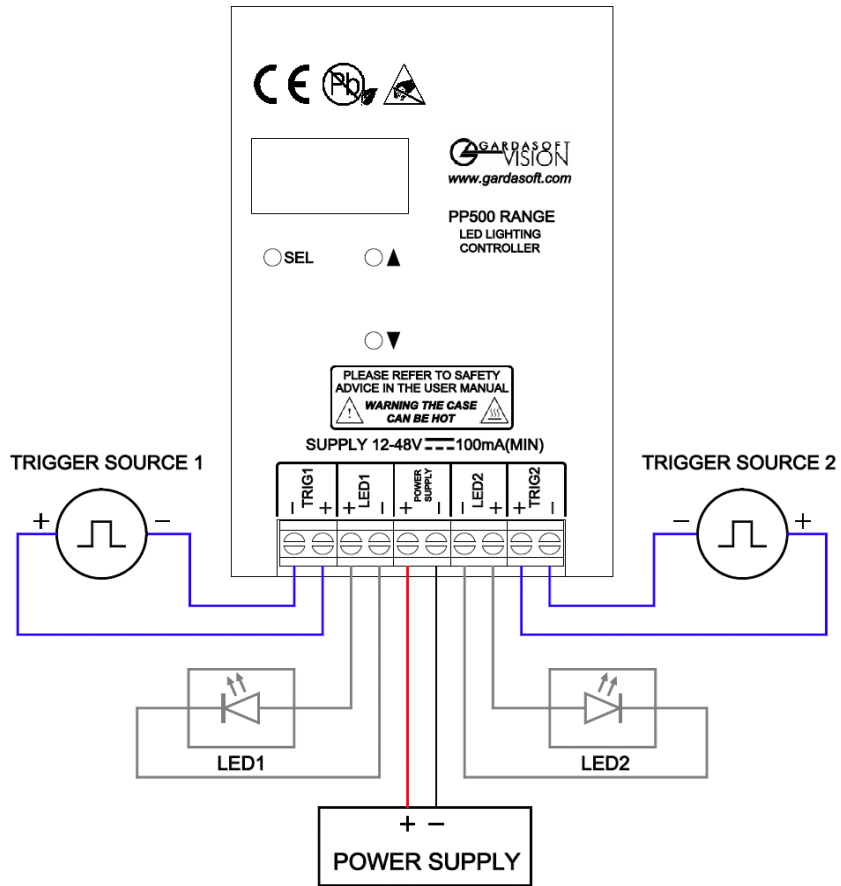

7 General Description

The PP500 current controller provides repeatable intensity control of LED lighting for machine vision applications. It includes the intensity control, timing and triggering functions required for machine vision systems.

LED lighting needs a constant current supply as small variations in voltage can cause large variations in light output. Currents can be specified in 2.5mA steps to give very fine control of intensity.

Three modes of operation are provided separately for each channel:

- **Continuous** (“SCo”):
In continuous mode the output is a continuous current.
- **Pulse (Strobe)** (SPu”):
In this mode output is pulsed once per trigger. One trigger input is used as a trigger. The delay and pulse duration can range from 20us to 1 second in 20us steps.
- **Switched** (“SON”):
In switched mode a trigger input can be used to switch the output current on and off. The output is only enabled when the trigger input has a voltage on it.

For Pulsed and Switched modes, either channel can be controlled by either trigger input.

The PP500 is set up using the push buttons and display on the front of the unit. The PP520/PP520F can also be set up using a Web Browser or using Ethernet commands. The set up is non-volatile, so the PP500 will resume the same operation after a power cycle.

7.1 Startup

On power up, the PP500 will display “b r” for five seconds, then ‘8.8.8.’ to test the display is working, then ‘PP5’, then ‘00’, ‘20’, ‘00F’ or ‘20F’, followed by the version number, eg ‘001’, and then will be ready for operation. To show that the unit is operating normally, an alternating pattern is drawn on the display. Once a light is connected, the controller will sense it, as described below.

7.2 Automatic Light Sensing

When a channel does not have a light connected, the PP500 continually tries to put out a very small current.

When a light is connected, it will flash for a short time (the light will not be damaged by this) until the PP500 detects that it is connected. The PP520 will send out an EVT message to the Ethernet (see GT command).

7.3 Output Modes

The trigger inputs are used as follows:

Mode	Trigger Input	Output
Continuous	Unused	Output is on.
Switched	Trigger = 0V	Output is off
	Trigger = 4.5V to 24V	Output is on
Pulsed	Rising edge	Pulse is triggered if P flag = 1 (default). See RE Ethernet command
	Falling edge	Pulse is triggered if P flag = 0

7.3.1 Continuous Output and Switched Output

In continuous mode the output current is fixed and continuous. Switched mode uses a trigger input to switch the output on or off.

In continuous and switched modes, the output current can be varied from 0% to 100% of full brightness.

7.3.2 Pulsed Output

The output is off by default. When the PP500 is triggered it will wait for a delay and then pulse the output. The delay, pulse width and pulse intensity are all configurable.

In pulsed mode, the brightness can be set up to 999% of its rating, but only for short periods and at low duty cycles, so that the lighting does not overheat and get damaged. The duty cycle is limited by ignoring triggers which are too soon after the previous trigger.

Output Brightness	Allowed Pulse Width	Allowed Duty Cycle
0 to 100%	999ms	100%
101% to 200%	30ms	30%
201% to 300%	10ms	20%
301% to 500%	2ms	10%
501% to 999%	1ms	5%

So for example, if the brightness is set to 350%, then the PP500 will not allow pulses greater than 2ms long. If a trigger occurs within 20ms of a previous trigger (so that the duty cycle would be greater than 10%) the trigger is ignored.

7.3.3 Fault Detection

The PP500 detects the following errors. Error detection can be turned off if required using the RE Ethernet command.

When the output current is less than 100mA, fault detection is turned off.

Error	Reason
PO	Internal power dissipation is too high. Output turned off.
OP	Output current to lighting is too low. The light is open circuit or there is not enough supply voltage for the requested output current.
SH	If the output voltage is too low, the controller detects that the output is short circuited.
HI	The voltage required for the lighting has increased too much. Check for ageing of the lighting or a failed LED.
LO	The voltage required for the lighting has decreased too much. Check for ageing of the lighting or a failed LED.

The user must press SEL to cancel the error (or send command "GR" using the Ethernet connection) and the PP500 will then re-sense the light and ask for confirmation of the current rating.

7.4 Cold Start

To clear the configuration to the default settings, turn on the PP500 while holding the SEL and DOWN buttons, for about 5 seconds, until 'COL' is displayed. Both channels are set up for 50% intensity, continuous operation.

The controller can be cold booted even when the keypad is locked. The lock is removed by the cold boot.

8 Keypad Configuration

The overall structure of keypad configuration is given to the right.

To configure the controller from the keypad, press and hold SEL for 1 second. 'CH1' will be displayed. Use UP and DOWN to select which feature to set up.

See the section on the Ethernet for setting up IP addresses.

Pressing and holding MODE at any time will cancel the operation.

8.1.1 Key Lock

The keypad can be locked so that unauthorised users cannot change the configuration. This can either be done with the KB Ethernet command or from the keypad. A lock code is used. Users who know the lock code can unlock the keypad. The lock code is from 0 to 255, providing moderate protection.

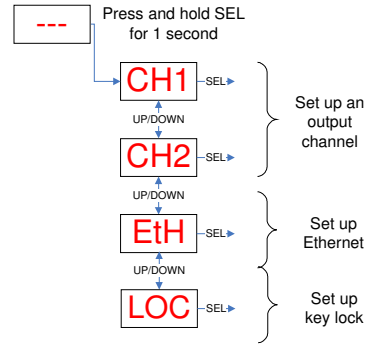

Unlocking

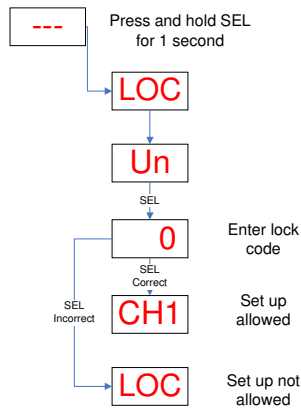

Locking

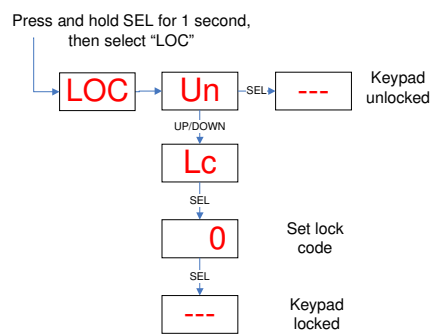

8.1.2 Setting Up Continuous and Switched Output

Continuous and switched output is set up as follows. Select “SCo” for continuous and “SOn” for switched operation.

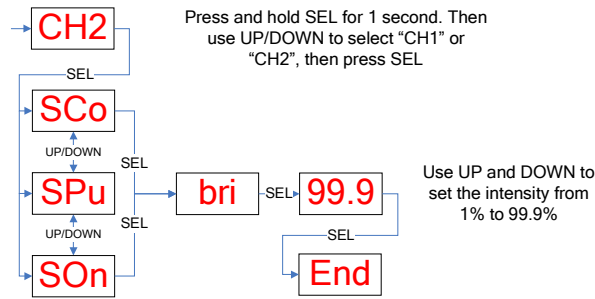

8.1.3 Setting Up Pulsed Operation

Pulsed operation can be set up as follows. If a brightness greater than 100% is selected, the pulse width will be limited to a safe value as in the table in Section 7.3.2.

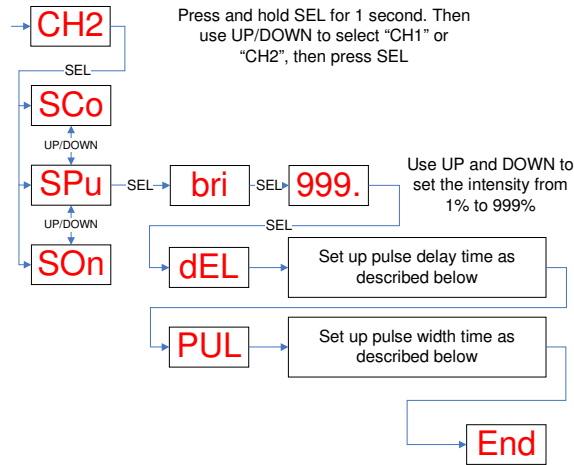

8.1.4 Setting Pulse Delay and Width Times

When the PP500 displays numeric values for the user to change, the right hand digit will be flashing to indicate that the Up and Down buttons can be used to change the value.

To be able to set pulse delay and pulse width values a scheme is used where the exponent (power of ten) of the value is set. The exponent values are as follows:

Exp value	Multiplier	Number format	Range of values
E-3	0.001	999.	Values are displayed in milliseconds from 1ms to 999ms in steps of 1ms.
E-4	0.0001	99.9	Values are displayed in milliseconds from 0.1ms to 99.9ms in steps of 0.1ms.
E-5	0.00001	9.99	Values are displayed in milliseconds PP500/PP520: 0.02ms to 9.98ms in steps of 0.02ms PP500F/PP520F: 0.01ms to 9.99ms in steps of 0.01ms
E-6	0.000001	999.	Values are displayed in microseconds PP500/PP520: 20us to 980us in steps of 20us PP500F/PP520F: 1us to 999us in steps of 1us

The flow diagram for entering timings on the keypad is given below.



When a light is pulsed, the display shows that a trigger has occurred by showing 'PUL' on the display.

9 Ethernet Setup (PP520, PP520F)

You may need to ask your network administrator for advice about setting up the Ethernet connection.

Ethernet set up is not affected by cold booting the PP520.

9.1 Connection

The Ethernet link uses a 10 base-T connection on an RJ45 connector. The PP520 will usually be connected to a network switch (or hub or router). It is also possible to connect it direct into the network port on a PC by using a crossover cable.

9.2 MAC Address

The PP520 MAC address is:

0x00.0x0B.0x75.0x01.0xNN.0xNN.

9.3 IP Address

The PP520 needs an IP address to communicate over Ethernet. There are two ways to get an IP address; either programmed into the unit or using DHCP.

Most networks use a DHCP server. If there is a PC on the network, You may be able to find out whether a PC on the same network uses DCHP as follows:

- Go to Control Panel
- Select Network Connections
- Right click on Local Area Connection. Select Properties
- From the list, select Internet Protocol (TCP/IP), press Properties

If “Obtain an IP address automatically” is set, then DHCP is probably used. However, there may be an alternative fixed IP address on the “Alternative Configuration” tab.

You can find out what IP address is being used by a PC at any time by:

- Go to Control Panel
- Select Network Connections
- Right click on Local Area Connection. Select Status
- Select the Support tab. The IP address is displayed

When using a fixed IP address, you must ensure that you use an IP address that is not being used by any other device on the network. It is usual to keep the first three numbers of the IP address the same as other devices and to change only the last number. For example, if you have a network consisting of a PC (IP address 192.168.1.35) and two PP520s, you might give them addresses 192.168.1.201 and 192.168.1.202.

9.3.1 Programmed IP Address and DHCP

For DHCP mode, the PP520 acquires its IP address, subnet mask and gateway address from a DHCP server. Otherwise the PP520 has a fixed IP address, subnet mask and gateway address.

Set DHCP mode from the keypad as follows. Press and hold the SEL button until the display shows “CH1”. Use the UP and DOWN buttons to select “ETH” then press SEL. The display will either show “FIP” for a fixed IP address or “dhC” for DHCP. Use the UP and DOWN buttons to select “dhC” and press SEL.

For a fixed IP address, select “FIP” and press SEL. The user will be prompted to enter four bytes of the IP address, four bytes of the address submask and then four bytes of the gateway address.

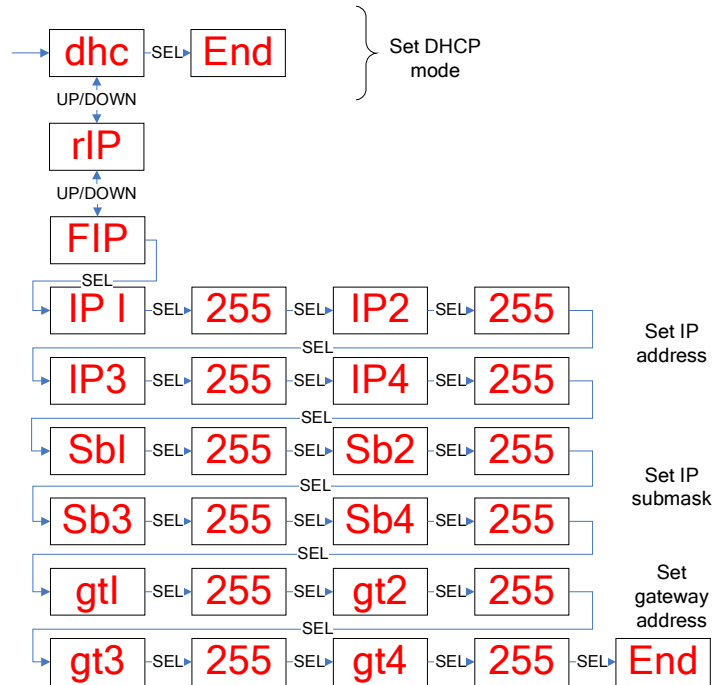

When an IP address has been assigned using DHCP, the address can be read from the keypad as follows. Press and hold the SEL button until the display shows “OP1”. Use the UP and DOWN buttons to select “ETH” then press SEL. Use the UP and DOWN buttons to select “rIP” and press

SEL. Keep pressing SEL and read the four values of the IP address. The example below shows the IP address 192.168.1.71.

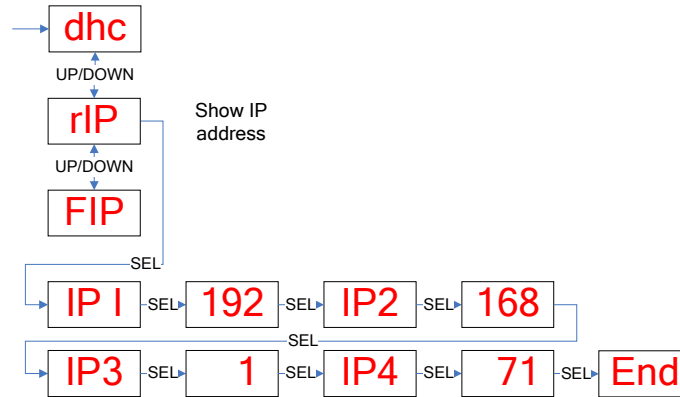

The IP address can also be detected using the Demonstration Program available for download at www.gardasoft.com.

10 Communication (PP520, PP520F)

All the features below are implemented in a demonstration program available from www.gardasoft.com.

10.1.1 Automatic Sensing

The PP520 will send out a message on three events:

- On power up
- When an IP address is received or renewed by DHCP
- When an enquiry message is received

On the first two events, the message is broadcast. On the third it is a reply to a single IP address.

An enquiry message is a UDP packet from source port 30310, destination port 30311 with the message body "Gardasoft Search" (8-bit ASCII, 13 characters).

The message output by the PP520 is a UDP packet from source port 30311, destination port 30310. It is formatted as:

```
Gardasoft,PP520,000000,111111111111,22222222
```

(8-bit ASCII, 44 characters), where

000000	the serial number of the unit
111111111111	the MAC address in 6 HEX bytes
22222222	the IP address in 4 HEX bytes

For example for PP520 serial number 12345, IP address 192.168.1.103, MAC address 00.0B.75.01.80.99 the packet will contain

```
Gardasoft,PP520,012345,000B75018099,C0A80167
```

11 Webpage Configuration (PP520, PP520F)

The PP520 has a small webserver inside, so that it can be configured from a standard web browser, such as Internet Explorer.

The IP address of the PP520 must be known (see the section on “Ethernet Setup.” Open a web browser window and type the IP address (for example 192.168.1.71) of the PP520 into the URL box at the top. The main page of the PP520 webserver should be shown.

11.1 Main Page

The main page shows general information about the PP520. Links are provided to the configuration pages.

11.2 General Setup Page

The general setup page allows various parameters to be set up and the webpage password to be set.

There is also a text box where any command (see section 12) can be entered.

11.3 Channel Configuration Pages

There is one Channel Configuration Page for each output channel. All the parameters for each output channel can be set up. Press the Submit button to update the PP520 and save the changes to non-volatile memory.

The current rating for the light can be changed. Use this with care.

Some measured voltages and the actual output current are displayed on this page.

12 Ethernet Configuration (PP520, PP520F)

12.1 Communication

The PP520 can be configured via the Ethernet connection using UDP or TCP/IP. A demonstration program with source code can be downloaded from www.gardasoft.com.

Communication consists of commands sent by the host (controlling PC). All output generated by the command is returned in reply UDP or TCP/IP packets. The last character sent is ">" ("greater than" symbol). Once this is received, the host knows that the command has been completed.

It is recommended that the host waits for the ">" symbol before sending the next command. UDP communications are not guaranteed to arrive, so the host software must be able to cope with lost messages.

Using the GT command, a host can request that a message is sent to it whenever an error occurs.

For TCP, commands from a host should be sent to destination port 30313. Replies will be to destination port 30312. For UDP, commands from a host should be sent from source port 30312 to destination port 30313. Replies will be sent from source port 30313 to destination port 30312.

A TCP/IP connection will timeout and close if it is idle for more than 10 seconds. The host must send regular "heartbeat" commands (eg "VR") to keep the link open.

12.2 Demonstration Program

A demonstration program is available from www.gardasoft.com which allows the PP520 to be configured using the commands below.

12.3 Command Structure

Several commands can be put into one command line by separating them by a semi-colon (;). A carriage return character should be sent to terminate the command line. The PP520 will send any replies to the commands and then send a '>' character to indicate that the command line has been completed.

Commands comprise a code of two letters followed by the parameters (if any) needed for the command. Spaces in the commands are ignored.

Numeric parameters are separated by a comma (","). For a parameter which is a time period the default units are milliseconds. "s", "ms" or "us" can be added to the end of the number to indicate seconds, milliseconds or microseconds. For currents, "a" or "ma" can be added to indicate "amps" or "milliamps". **The default is amps.**

Note that parameters are in "USA/UK" format so that a half is written "0.5" not "0,5"

For example:

Parameter	Meaning
0.1	0.1 milliseconds
200us	200 microseconds
0.1s	0.1 seconds
100ma	100mA
2.45A	2.45A
2.3	2300mA or 2.3A

The command codes and their meaning are described below. The upper case commands are shown, followed by lower case letters denoting the numeric argument.

Error number	Reason
Err 1	A parameter value is invalid
Err 2	Command not recognised
Err 3	Numeric value is wrong format
Err 4	Wrong number of parameters
Err 5	(Warning only) A timing parameter was out of range and has been adjusted.

Any changes made using Ethernet commands are not saved permanently until the AW command has been issued.

12.3.1 General Commands

Save the settings to memory.

AW

Once the settings are saved to memory they are then retained when the unit is switched off. If this is not done, changes to the settings are volatile, and if the unit is switched off they revert to those in force when the last AW command was issued.

Report the configuration

ST

Typical output is:

CH 1, MD 1, CS 1.000A, SE 999.00, DL 0.00ms, PU 0.10ms, PW 0, ST 2, EV 2.0V

CH 2, MD 1, CS 0.100A, SE 100.00, DL 0.00ms, PU 1.00ms, PW 0, ST 2, EV 19.3V

Where the numeric values are:

- CH Channel number
- MD Mode: 0 = continuous, 1 = pulse, 2 = switched
- CS Current rating of the light
- SE Brightness percentage setting
- DL Pulse delay
- PU Pulse width
- PW, ST Unused
- EV Expected voltage across lighting

Enable Ethernet Messages

GTm

- m = 0 to disable Ethernet messages
- m = 1 to enable Ethernet messages

When Ethernet messages are enabled, any error reports are sent to the most recent UDP or TCP address from which a command has been received.

If Ethernet messages are enabled, when a light is connected and the user is being prompted to enter the current rating, the PP520 will send one of these two messages:

- Evt016 (if channel 1 detected)
- Evt017 (if channel 2 detected)

An application can send an RR command back in reply, which will cancel the user prompt.

Read any error messages

GR

If Ethernet messages are not enabled, the last error number can be read by this command. Any error displayed on the unit is cleared, so if there was a lighting error, the PP520 will resume auto-sensing on that channel.

The reply is of the form:

- Err 45 Error 45 was the last error
- Err 0 No error has occurred since the last GR command

Set/Clear the Webpage Password

EY

EY asc1, asc2, asc3, asc4, asc5, asc6

This command sets the password required to access the webpages. If EY is entered on its own then the password is cleared. There are six optional parameters, which are ASCII values for a password from one to six letters. A value of 65 is 'A', 66 is 'B', etc to 90 is 'Z'.

Report the version of firmware running in the PP520

VR

This command returns the firmware version. For example:

PP520 (HW001) V002

Set the SafeSense Mode

REc,m

Where:

c = output channel (1 or 2)

m = SafeSense mode:

bit 0 = 0 S flag set (prompt for current rating enabled)
 1 S flag cleared (prompt for current rating disabled)
 bit 1 = 0 E flag set (error detection enabled)
 1 E flag cleared (error detection disabled)
 bit 2 = 0 P flag set (positive triggers)
 1 P flag cleared (negative triggers)

Set the Trigger Input

This command sets which input is used for pulse and switch output modes.

RPC,p

Where:

c = output channel (1 or 2)

p = trigger input (1 or 2)

Set the output current rating

This command changes the current rating for a light.

RRC,v

Where:

c = output channel (1 or 2)

v = rated current (10mA to 2A)

Set continuous mode

The output is set to continuous mode at a percentage of full brightness.

RSc,s

Where:

c = output channel (1 or 2)

s = setting in percent (s = 0 to 100)

Set switched mode

The output is set to switched mode at a percentage of full brightness.

RWc,s

Where:

c = output channel (1 or 2)

s = setting in percent (s = 0 to 100)

Set pulse mode

The output can be set up to pulse on a trigger input. The delay from trigger to the start of the pulse, the length of the pulse and the brightness are configurable.

An error is generated if the brightness setting requires a current greater than 10A or if the combination of pulse width and setting is not allowed.

RTc,p,d,s

Where:

c = output channel (1 or 2)

p = pulse width in milliseconds (0.02 to 999)

d = delay from trigger to pulse in milliseconds (0.02 to 999)

s = setting in percent (s = 0 to 999)

Simulate an Input Trigger

TRc

c which input channel (1 or 2)

Simulates a trigger pulse. If the channel is in pulse mode it will pulse and show "PUL" on the display.

Disable Keyboard

KBd,c

d = 0 Enable keyboard

d = 1 Disable keyboard

c Unlock code

In some applications it may be necessary to disable the keyboard so that operation can only be controlled from the Ethernet port. The setting of this command is restored after a power cycle.

12.3.2 Command Summary

Command	Example	Effect
AW	AW	Save changes
ST	ST	Show configuration
GT	GT1	Enable Ethernet messages
GR	GR	Get any error codes
EY	EY65,66	Set webpage password to "AB"
VR	VR	Red the firmware version
RR	RR1,0.2	Set the rating of channel 1 to 0.2A
RS	RS2,65	Set channel 2 to 65% brightness continuous
RW	RW1,50	Set channel 1 to 50%, switch mode
RT	RT2,3,4,50	Set channel 2 to 3ms pulses, delayed by 4ms, at 50% brightness
KB	KB1	Disable the buttons on the front panel
TR	TR2	Trigger channel 2
RP	RP1,2	Output channel 1 is triggered using input 2
RE	RE1,3	Set channel 1 to ignore lighting errors and not prompt for the current rating of a light when it is connected

A. Specification

Parameter	Value	Notes
Digital supply voltage (PSU+)	12V DC to 48V DC regulated	Must be at least 1V greater than the load potential difference at maximum required current
Supply current with no lights connected	150mA	This is with a 12V supply. The current is lower at 24V.
Trigger input voltage	Logic 0: < 1V Logic 1: 4.5V to 24V	This is the voltage applied between the positive and negative of each input
Typical trigger input current required	3mA at 4.5V. 22mA at 24V	
Maximum output current per channel	2A continuous or 10A pulsed	
Maximum total output current	2A average	
Ambient temperature during operation	5°C to 50°C	The ambient temperature may need to be lower if the PP500 is dissipating a lot of heat
Total allowed power dissipation without heatsinking	8 Watts max without heatsinking	See Section for information on heat dissipation
Pulse Timing	20us to 1 second	PP500, PP520
	1us to 1 second	PP500F, P520F
Delay Timing	20us to 1 second	PP500, PP520
	4us to 1 second	PP500F, P520F

B. Timing

The following timings apply for firmware revision V014.

A.1 Switched Mode

The maximum delay from a trigger input changing to the output current being turned on or off is 10us.

A.2 Pulse Mode

For the PP500F and PP520F the minimum pulse delay is about 4us.

C. Firmware Upgrade

On the PP520 and PP520F the firmware can be upgraded using the Ethernet interface. Contact your distributor for more information.

D. Fatal Error Codes

Error number	Reason
FAt	The PP500 is too hot. The PP500 has a thermal cutout. If the internal temperature reaches 62°C, which corresponds to a case temperature of approximately 70°C, the output currents are turned off. This message will persist until the PP500 has cooled down below 62°C.
FAC	One channel is outputting more current than expected.

E. Error Codes

Error number	Reason
Err 1	A parameter value is invalid
Err 2	Command not recognised
Err 3	Numeric value is wrong format
Err 4	Wrong number of parameters
Err 5	One of the parameters is out of range. The value of the parameter has been adjusted. For example, sending an RT command with a delay of 0 will get a reply of "Err 5". When the settings are viewed the delay will have been set to 20us (PP500 or PP520) or 4us (PP500F, PP520F).
Err 8, 12	EEPROM corrupt. The configuration has been cleared.
Err 20	Couldn't save settings to EEPROM.
Err 27	Can't read Ethernet settings from EEPROM, so these may be incorrect.
PO, Err 34	Internal power dissipation is too high. Output turned off.
OP, Err 35	Output current to lighting is too low.
OP, Err 39	There is not enough supply voltage for the requested output current.
SH, Err 36	The output is short circuit.
HI, Err 37	The voltage required for the lighting has increased too much. Check for ageing of the lighting or a failed LED.
LO, Err 38	The voltage required for the lighting has decreased too much. Check for ageing of the lighting or a failed LED.

Any other errors are internal errors.

F. Gardasoft LED Lighting Controllers

The products available at the time of writing include the following. Other products are also available. See www.gardasoft.com for details of the current range.

PP500 Range

- 2 output channels up to 10A each
- 2 digital inputs
- Front panel configuration

PP500 Lighting controller
PP520 Lighting controller with Ethernet control
PP500F Lighting controller with fast pulsing
PP520F Lighting controller with Ethernet control, fast pulsing
PP701 DIN Rail mounting clip for PP500 and PP500F ranges

PP420 Range

- Same as the PP500 range but with 4 channels, no front panel

PP420 Lighting controller with Ethernet control
PP420F Lighting controller with Ethernet control, fast pulsing

PP820 Range, PP860C Range

- High current, high accuracy controller
- 8 output channels up to 20A each
- Pulses repeatable to 0.1 microseconds
- RS232 or Ethernet configuration

Machine Vision Timing Controller

CC320 Controller

- 8 digital inputs
- 8 digital outputs
- 1, 2, or 3 wire Encoder input
- Very flexible operation
- Ethernet control
- Front panel configuration

PP703 DIN Rail mounting clip for CC320