



CC320

Trigger Timing Controller



USER MANUAL

Revision 05

Gardasoft Vision Ltd
Castle Acres, Elsworth
Cambridge, CB23 4JQ, UK
Tel: +44 1954 200343
Fax: +44 1954 204343
Web: www.gardasoft.com

1	DISCLAIMER	3
2	SAFETY	3
3	GETTING STARTED	4
4	MECHANICAL FIXING	5
5	CONNECTIONS.....	6
5.1	GENERAL.....	6
5.2	POWER SUPPLY.....	6
5.3	DIGITAL INPUTS.....	6
5.4	DIGITAL OUTPUTS	7
6	OPERATION	8
6.1	INPUT MODES	8
6.2	OUTPUT MODES.....	9
6.3	EXAMPLES.....	12
6.4	COLD BOOT	18
6.5	CONFIGURATION FORM	19
7	KEYPAD CONFIGURATION	20
7.1	STARTUP.....	20
7.2	COLD START.....	20
7.3	CONFIGURATION.....	20
8	ETHERNET SETUP	25
8.1	CONNECTION	25
8.2	MAC ADDRESS	25
8.3	IP ADDRESS.....	25
9	WEBPAGE CONFIGURATION.....	29
9.1	MAIN PAGE.....	29
9.2	CHANNEL CONFIGURATION PAGES.....	29
10	UDP AND TCP/IP CONFIGURATION	30
10.1	COMMUNICATION	30
10.2	COMMAND STRUCTURE	30
10.3	COMMANDS	31
10.4	COMMAND SUMMARY	34
A.	TIMING.....	35
B.	ERROR CODES	35

1 Disclaimer

Except as prohibited by law:

- All hardware, software and documentation is provided on an “as is” basis.
- It is essential that the user ensures that the operation of the product is suitable for their application.
- The user must ensure that incorrect functioning of this equipment cannot cause any dangerous situation or significant financial loss to occur.
- Gardasoft Vision Ltd and Gardasoft Products Ltd will not accept any liability for consequential loss of any kind.

All trademarks acknowledged.

Hardware, software and documentation are Copyright 2007 Gardasoft Products Ltd. Hardware manufactured by Gardasoft Vision Ltd under license.

2 Safety

2.1.1 General

Please read this before using the CC320 family of products. If in doubt, contact your distributor or Gardasoft Vision.

The CC320 must not be used in an application where its failure could cause a danger to personal health or damage to other equipment.

If the equipment is used in a manner not specified by the manufacturer, the protection provided by the equipment may be impaired.

2.1.2 Electrical

The user must ensure that the potential difference between any combination of applied signals does not exceed the supply voltage. **WARNING:** Higher voltages may cause a danger to personal health.

The CC320 does not have complete tracking isolation of inputs and outputs.

Transients caused by inductive loads must be suppressed external to the CC320.

3 Getting Started

Read the sections on Safety and Operation and check the CC320 fulfils your requirements.

Mount the CC320 as described in “Mechanical Fixing” using a DIN rail or the mounting holes.

Connect the CC320 as in the section on Connections. When the CC320 powers up it should show two alternating lines on the display to indicate that it is operating properly. Three indicator LEDs on the outputs should be pulsing in sequence every second.

Check that inputs and outputs are working correctly as described in Troubleshooting.

If required, connect Ethernet to the CC320 and set it up according to the Ethernet section.

Read the section on “Operation.” Use the keypad, a web browser or the CC320 demo program (available from www.gardasoft.com) to configure the unit.

Visit www.gardasoft.com for Application Notes giving additional information on the use of the CC320.

Throughout this manual, references to the CC320 refer to all variants in the CC320 range unless otherwise stated.

The symbol “s” is used to indicate seconds, “ms” for milliseconds and “us” for microseconds.

4 Mechanical Fixing

The CC320 does not have an IP rating and should be mounted so that moisture and dirt cannot enter the unit.

The maximum operating temperature is 5°C to 60°C.

The CC320 can be mounted onto a panel using the threaded holes in the base, see diagram below. The PP703 kit is available for mounting the CC320 on a DIN rail. The top drawing shows the optional DIN rail fitted. Dimensions are in millimetres.

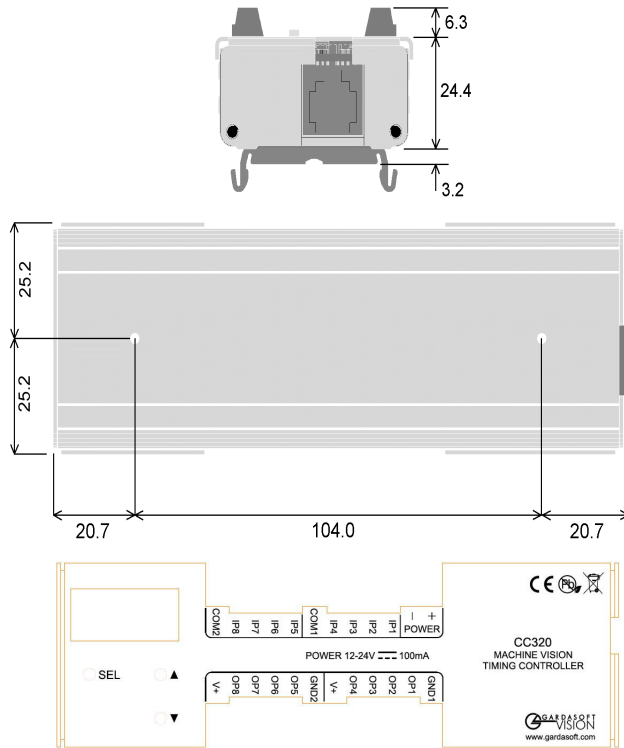

The CC320 enclosure is a fire enclosure as long as the following conditions are met:

- The Ethernet connector must not be facing downwards
- The mounting holes on the underside must be covered or have a screw fitted.

5 Connections

5.1 General

All connections except Ethernet are available on screw terminals.

5.2 Power Supply

The power supply must be 12VDC to 24VDC regulated. The maximum current required is 100mA. The maximum heat dissipation is 2.4W.

5.3 Digital Inputs

The state of each input is shown on an LED next to the connector.

Digital inputs are opto-isolated. They consist of a 2K resistor and a 1.5V LED. If the voltage across an input is less than 2V then it is a logic 0. If the voltage is 5V to 24V then it is a logic 1. At 5V the current drawn by the input will be 1.8mA and at 24V will be 11.3mA.

The inputs have a common negative connection, in two groups of four.

Connector	Function
POWER +	Power supply 12V to 24V
POWER -	Power supply 0V
IP1	Input 1 positive
IP2	Input 2 positive
IP3	Input 3 positive
IP4	Input 4 positive
COM1	Common negative for inputs 1, 2, 3, 4
IP5	Input 5 positive
IP6	Input 6 positive
IP7	Input 7 positive
IP8	Input 8 positive
COM1	Common negative for inputs 5, 6, 7, 8

5.4 Digital Outputs

The state of each output is shown on an LED next to the connector.

Digital outputs are open drain with a series 20 Ohm resistor. The voltage across the output must not be greater than 24V and the output can only sink up to 50mA. If the output is shorted to a voltage higher than 5V then the output may be damaged.

Do not draw more than 50mA from the +VE connections as this will affect the internal operation of the controller.

Connector	Function
GND1	Common 0V for outputs 1, 2, 3, 4
OP1	Output 1 open drain
OP2	Output 2 open drain
OP3	Output 3 open drain
OP4	Output 4 open drain
+VE	3.3V regulated output. Maximum source current 50mA.
GND2	Common 0V for outputs 5, 6, 7, 8
OP5	Output 5 open drain
OP6	Output 6 open drain
OP7	Output 7 open drain
OP8	Output 8 open drain
+VE	3.3V regulated output. Maximum source current 50mA.

5.4.1 Ethernet Connector

The RJ45 Ethernet connector requires a straight through cable to connect into a network switch, hub or router. It runs at 10Mbits per second.

6 Operation

The CC320 Trigger Timing Controller has eight digital inputs and eight digital outputs.

All outputs operate independently and are configured separately. Configuration is very flexible to provide solutions for a wide variety of timing problems.

The configuration can be saved in non-volatile memory so that the CC320 will resume operation after a power cycle.

The state of each input and output is shown on an LED next to the connector. Pulses are stretched – a 10us pulse will be shown as a 100ms pulse on the LED, so that it is visible to the user.

6.1 Input Modes

All inputs are general purpose trigger inputs except for IP1, IP2, IP3, which can be used for an encoder or an general inputs.

6.1.1 Encoder Operation

The CC320 supports three types of encoder. The maximum encoder signal frequency is 200KHz.

Mode	Connections	Operation
EN 1 - one wire encoder	IP1 is QEA	Simple encoder provides position information. All movement is assumed to be forward.
EN 2 – two wire encoder	IP1 is QEA IP2 is QEB	Quadrature encoder provides position and direction information.
EN 3 – three wire encoder	IP1 is QEA IP2 is QEB IP3 is Index	As EN 2, with an index pulse to reset the position. NOT IMPLEMENTED YET.

For 2 and 3 wire encoders the CC320 will handle reversed movement correctly. When the belt is in a reversed position:

- the letter “b” will be displayed on the front panel
- triggers for PEt and PEE modes (see below) will be ignored
- output pulses in PtE, Pet and PEE modes will not be duplicated

In 3-wire mode, the number of pulses per revolution and an options value (to be defined) must be entered.

6.1.2 Free Running Trigger

An internal input (IP0) can be used as a periodic trigger.

The following parameter can be set.

Parameter	Use
Period	The period (inverse of the frequency) of the simulated trigger. 0 disables the simulated trigger.

For example a period of 20ms could be set, which would result in a 50Hz trigger. This can be used to trigger pulses on any of the outputs.

6.2 Output Modes

Each output operates independently. By combining which outputs are triggered by which inputs and which mode each output is in, it is possible to configure complex sequences of operation.

Several outputs can be triggered by one input to give synchronous operation, or from separate inputs to give asynchronous operation of different functions.

For each output, the following parameters can be set.

Parameter	Use
Mode	Specifies how the output operates.
Input	Specifies which input is used for triggering.
Gate Input	Specifies an input which enables/disables the output. This is also used to specify the number of pulses in "burst" mode.
Pulse Delay	Specifies the delay from trigger to pulse output. This can either be a time period or a number of encoder pulses, depending on the mode.
Pulse Width	Specifies the width of the pulse output. This can either be a time period or a number of encoder pulses, depending on the mode.
Retrigger time	The retrigger time is the minimum time from when an output is triggered to the next time. This can be used to debounce noisy inputs or when a product sensor fires more than once for one product. The retrigger time uses the same dimension (encoder pulses or time period) as the Pulse Delay.
Flags	Specifies other options.

When pulsing, the Pulse Delay and Pulse Width parameters can either be fixed times or can be a number of encoder pulses.

The following operating modes are available for each output. The Mode Number is used for Ethernet commands. The Mode Name is used when configuring using the keypad.

Mode	Mode Name	Operation
0	OFF	The output is set off. If the output is inverted (flag O is set) then the output will be logic 1, otherwise logic 0.
1	On	The output is set high (on). If the output is inverted (flag O is set) then the output will be logic 0, otherwise logic 1.
2	Ptt	Pulsed output triggered by a digital input. The delay and pulse width are set as fixed times.
3	PtE	Pulsed output triggered by a digital input. The delay is a fixed time. The pulse width is a number of encoder pulses.
4	PEt	Pulsed output triggered by a digital input. The delay is a number of encoder pulses. The pulse width is a fixed time.
5	PEE	Pulsed output triggered by a digital input. The delay and pulse width are a number of encoder pulses.
6	Pd	Pulse divider. Every <Pulse Delay> trigger pulses, the output is pulsed for <Pulse Width> time.
7	Enc	Pulsed output triggered by encoder pulses. The output is pulsed for <Pulse Width> encoder pulses with the pulses separated by <Pulse Delay> encoder pulses. The Input and Gate Input parameters are not used.
8	bur	Burst output. When triggered, <Gate Input> pulses are output. Each pulse is <Pulse Width> long and the time between the start of one pulse and the next is given by <Pulse Delay>. The maximum number of pulses that can be output is 250.
9	FrE	Outputs a constant high frequency square wave. The frequency is configurable. Further details available from Gardasoft.
10	buF	Buffer an input by making the output the same signal as the input. If there is gate input set, then the gate input signal enables the output – if the gate input is off then the output is off. Flag O inverts the output and Flag G inverts the gate input.

Each output also has the following flags which specify other options. For Ethernet commands, multiple flags can be set by adding the flag values together.

Flag value	Flag Name	Operation when flag = 0	Operation when flag = 1
1	I	Trigger off leading edge of input.	Trigger off trailing edge of input.
2	O	Output is normally low, going high when pulsing.	Output is inverted. It is normally high, going low when pulsing.
4	G	If a gate input is specified, the input must be high to enable triggers.	If a gate input is specified, the input must be low to enable triggers.
8	E	No Ethernet message.	Send message on Ethernet when triggered.
16	F	Triggers are ignored until output pulse is complete.	FIFO output mode. Multiple triggers are queued up.
32	R	Resync mode disabled.	Resync Mode enabled.
64	P	Default to pulse in resync mode.	Default to no pulse in resync mode.

6.2.1 Burst Mode

In burst mode, an output will pulse several times in response to a trigger. The periods are timed (not encoder counts).

The following parameters are used:

- Mode is 8 for burst mode
- Gate Input specifies the number of pulses (1 to 250)
- Pulse Width specifies the pulse width
- Pulse Delay specifies the separation between the start of one pulse and the start of the next

Pulse Delay must be longer than Pulse Width.

6.2.2 Ethernet Message Flag (E)

When the CC320 is used to trigger a camera, the image processing can either be triggered by the acquisition of an image or by an Ethernet message sent from the CC320.

When a trigger is received it is assigned a unique tag (an incrementing number from 0 to 255). Using the GT Ethernet command and the Ethernet Message flag, the CC320 will send the unique tag in a message to the host computer to say that a trigger has occurred.

6.2.3 Resync Flag (R)

Reject gate operation usually needs to be synchronised to the original product trigger. However image processing can take a variable length of time to complete, so rejects based on when the

processing result is available will not be accurately timed. The Resync flag allows pass/fail results to be re-synchronised to the original trigger.

There are two types of reject gate:

- A pulse is required to reject a product (set the P flag)
- A pulse is required to stop a product being rejected (don't set the P flag)

The Resync Flag should be used with the Ethernet Message flag. The host computer will receive a unique tag message, process the image and then send a pass/fail result (as an SN command) back to the CC320. The CC320 will match the message to the original trigger and time the pass/fail output pulse accurately.

If an SN command is not received in time, then the product will be rejected, and an error code output.

6.2.4 FIFO Flag (F)

The FIFO flag is used for systems where there can be more than one product between the trigger point and reject gate. This is usually used with the Resync flag, so that each product has its own pass/fail result.

If the FIFO flag is not set, then an output cannot be re-triggered until the previous pulse has completed. Others triggers in this time will be ignored.

If the FIFO flag is set, then multiple triggers are stored in the CC320 and a pulse is generated for each trigger at the correct time.

6.2.5 Pulse Flag (P)

The Pulse flag is used to select whether a pulse is needed to reject or to accept a product when the Resync flag is set. When not set, a pulse is required to reject product. If a pass/fail message is not received in Resync mode, the CC320 will default to rejecting the product.

6.3 Examples

6.3.1 Sequenced Pulses

A sensor detects product presence. There are two cameras which need to take an image after different delays. The leading edge of IP1 is used as the trigger. OP1 triggers the first camera after 100ms. OP2 triggers the second camera after 200ms. Both camera triggers are positive pulses.

Output	Mode	Input	Gate Input	Pulse Delay	Pulse Width	Retrigger Time	Flags
1	2	1	0	100ms	100us	0	0
2	2	1	0	200ms	100us	0	0

Both outputs are set into pulse mode. Two different delays give the timing difference between the two cameras.

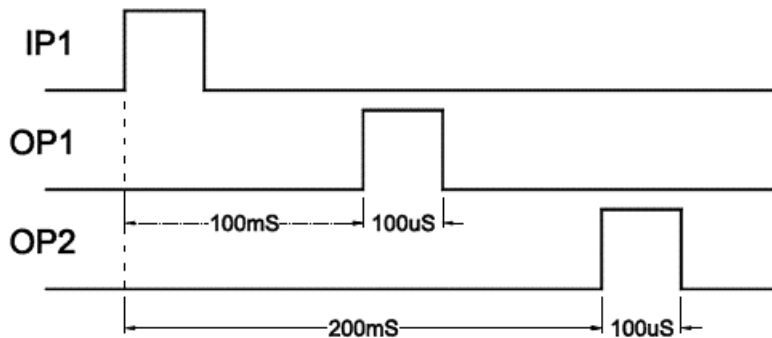

6.3.2 Gated Pulses

A camera needs to be triggered at 25Hz continuously, except when IP1 is high to indicate that the machine has stopped. The camera is triggered on OP1.

Output	Mode	Input	Gate Input	Pulse Delay	Pulse Width	Retrigger Time	Flags
1	2	0	1	0ms	100us	0	G (4)
Set free running trigger to 25Hz.							

OP1 will trigger continuously at 25Hz only when IP1 is low. Note that Flags = 0x04 to invert the sense of IP1. If Flags = 0x00, then OP1 will only trigger when IP1 is high.

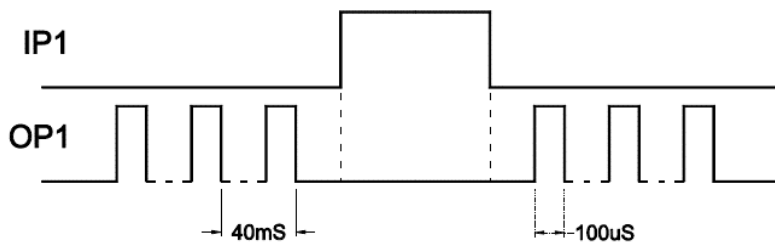

6.3.3 Belt Position Triggering

On a conveyor with an encoder, a sensor detects product presence. There are two cameras which need to take an image at fixed distances along the belt. The camera trigger pulses must be fixed width for exposure control. The trailing edge of IP4 is used as the trigger. OP1 triggers the first camera after 100ms. OP2 triggers the second camera after 200ms. Both camera triggers are negative pulses.

Output	Mode	Input	Gate Input	Pulse Delay	Pulse Width	Retrigger Time	Flags
1	5	4	0	2000 encoder counts	100us	0	I, O (3)
1	5	4	0	4000 encoder counts	100us	0	I, O (3)
Set input mode to 3-wire encoder.							

Both outputs are set into pulse mode. The pulse delay is a number of encoder pulses and the pulse width is a fixed time. The flags specify the trailing edge of the trigger signal and that the output pulse is active low.

DIAGRAM TO BE INSERTED

6.3.4 Pulse Burst

A sensor on IP1 detects product presence. Four images need to be taken from one camera using four different lights at 40ms intervals. OP1, OP2, OP3, OP4 are used to output triggers to turn on the four lights in sequence. OP5 is used to trigger the camera four times.

Output	Mode	Input	Gate Input	Pulse Delay	Pulse Width	Retrigger Time	Flags
1	2	1	0	0ms	40ms	0	0
2	2	1	0	40ms	40ms	0	0
3	2	1	0	80ms	40ms	0	0
4	2	1	0	120ms	40ms	0	0

5	8	1	4	40ms	100us	0	0
---	---	---	---	------	-------	---	---

OP1 to OP4 are pulsed for 40ms in sequence. As each one is pulsed, OP5 is also pulsed for a short time to trigger the camera (Gate Input = 4 specifies four pulses).

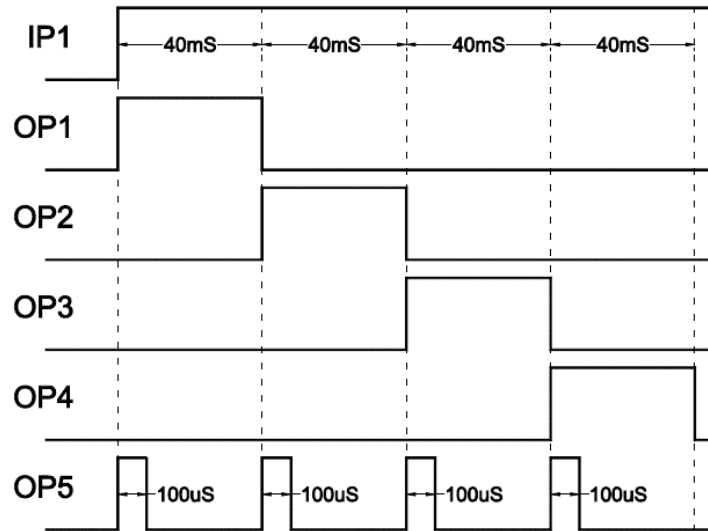

6.3.5 Simple FIFO Mode

A sensor on IP1 detects product presence. After a delay OP1 triggers a camera. There may be several products between the sensor and the camera.

The CC320 needs to store each of the triggers and then output a pulse after the correct delay.

Output	Mode	Input	Gate Input	Pulse Delay	Pulse Width	Retrigger Time	Flags
1	2	1	0	10 seconds	100us	0	F (16)

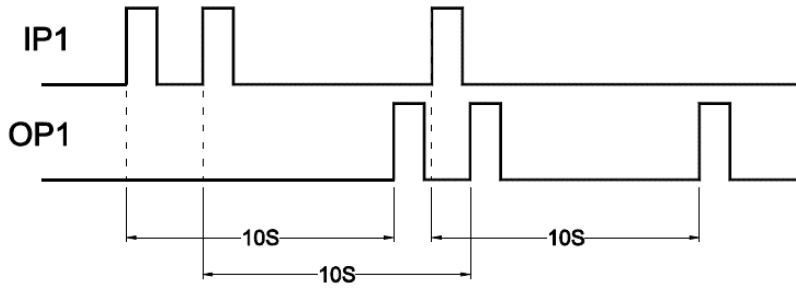

6.3.6 Resync Mode

A sensor on IP1 detects product presence. After a delay OP1 triggers a camera. Image processing software processes the image (which can take a variable length of time) and then sends a pass/fail message to the CC320. The pass/fail is re-synchronised to the original product presence and the reject gate is opened if necessary.

The reject gate is on OP2 and pulses high to reject the product. Products take 10 seconds to travel from the sensor to the reject gate and take 1 second to move past the reject gate.

Output	Mode	Input	Gate Input	Pulse Delay	Pulse Width	Retrigger Time	Flags
1	2	1	0	200ms	100us	0	E (8)
2	2	1	0	10 seconds	1 second	0	R, P (96)

10 seconds after a trigger, OP2 is set to pulse for 1 second to reject a product.

The camera trigger has the "Send trigger message" flag set. So that when the camera is triggered, a message is sent to the image processing software. The image processing software must use the GT command to receive these messages.

The image processing has to send a pass/fail message before the reject gate is reached by the product. As well as "Resync mode" the "default to pulse" flag is set. This means that if the image processing software does not send a pass/fail message OP2 is pulsed anyway.

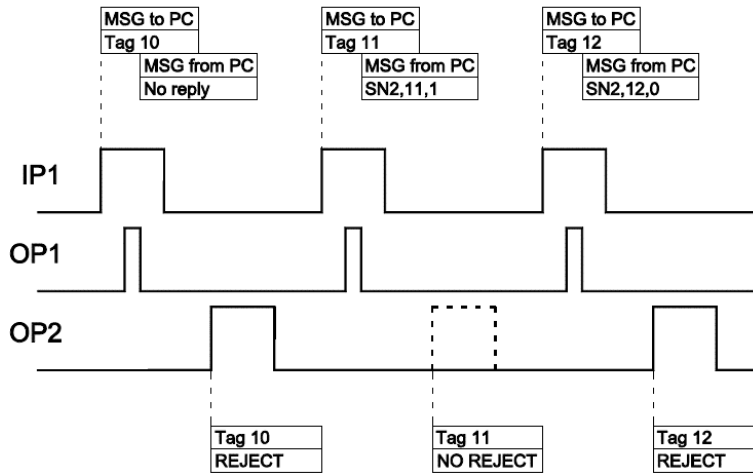

In this example, three product triggers were received. The camera was triggered using OP1.

A Tag10 Ethernet message was sent to the host computer when the first trigger was received, but for some reason a reply was not received, so the product was rejected for fail-safe operation. After the second trigger a Tag 11 messages was sent, with the reply “SN2,11,1” (OP2, tag 11, pass) so the reject pulse on OP2 was cancelled. After the third trigger a Tag 12 messages was sent, with the reply “SN2,12,0” (OP2, tag 12, fail) so the reject pulse on OP2 was not cancelled.

6.3.7 Resync and FIFO Mode

This uses the same situation as the previous example, but products are 4 seconds apart, so that when a product is detected, there are already two others travelling towards the reject gate.

Image processing software processes the image (which can take a variable length of time) and then sends a pass/fail message to the CC320. The pass/fail is re-synchronised to the original product presence and the reject gate is opened if necessary.

Output	Mode	Input	Gate Input	Pulse Delay	Pulse Width	Retrigger Time	Flags
1	2	1	0	200ms	100us	0	E (8)

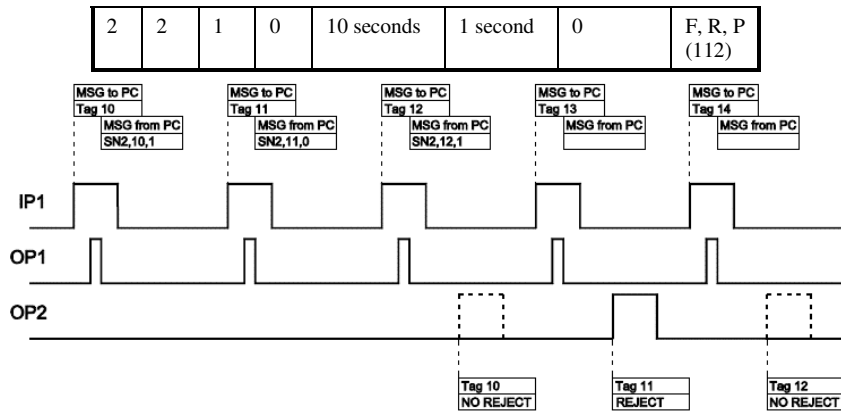

6.4 Cold Boot

A cold boot function is available to reset the CC320 to a known state. The unit can be cold booted as follows:

- Press and hold the SEL and DOWN buttons when powering up the unit
- Sending an Ethernet command
- Pressing a button on an internal webpage

When the unit is cold booted it is set to the following state:

- IP0 (free running trigger) is set up as a 1Hz internal trigger
- The unit is set up for no encoder input
- OP1 triggers from IP1, delay for 100ms then pulse for 100ms
- OP2 triggers from IP2, delay for 100ms then pulse for 100ms
- OP3 triggers from IP3, delay for 100ms then pulse for 100ms
- OP4 triggers from IP4, delay for 100ms then pulse for 100ms
- OP5 triggers from IP5, delay for 100ms then pulse for 100ms
- OP6 triggers from IP0, delay for 100ms then pulse for 100ms
- OP7 triggers from IP0, delay for 200ms then pulse for 100ms
- OP8 triggers from IP0, delay for 300ms then pulse for 100ms

6.5 Configuration Form

Before configuring the CC320, work out all the values and fill in a copy of the form below. This form is available on the CC320 page at www.gardasoft.com.

Output	Mode	Input	Gate Input	Pulse Delay	Pulse Width	Retrigger Time	Flags	Tick when complete
1								
2								
3								
4								
5								
6								
7								
8								
Free running timer period:								
Encoder mode:								

7 Keypad Configuration

The CC320 is set up using the push buttons and display on the front of the unit. The set up is non-volatile, so the CC320 will resume the same operation after a power cycle.

7.1 Startup

On power up, the CC320 will display “8.8.8.” to test the display is working, then “CC”, “320”, followed by the version number, eg “001”, and then will be ready for operation. To show that the unit is operating normally, a moving pattern is drawn on the display.

7.2 Cold Start

In the unlikely event that the non-volatile memory becomes corrupt the CC320 may not start up properly. In this case the memory can be cleared by powering up the CC320 while holding down the SELECT and DOWN buttons. The CC320 will display “COL” for about 2 seconds while the memory is cleared.

7.3 Configuration

To configure the controller from the keypad, press and hold SEL for 1 second. “OP1” will be displayed.

The overall structure of keypad configuration is given to the right.

The UP and DOWN buttons are used to change the selection and to change numeric values. The SEL button is used to confirm a selection and move to the next item. When configuration is complete, “End” is displayed.

See the section on the Ethernet for setting up IP addresses.

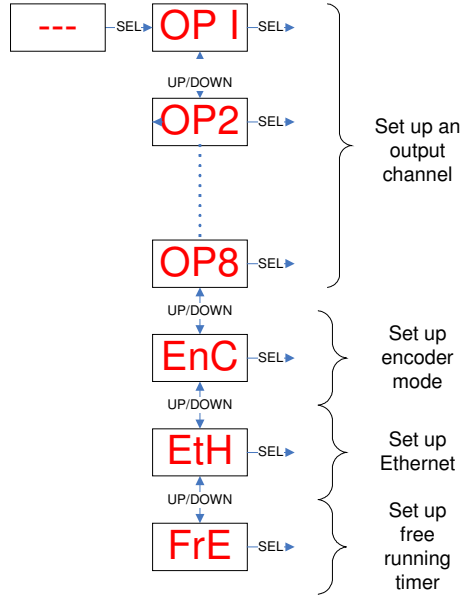

7.3.1 Setting Numeric Values

When the CC320 displays numeric values for the user to change, the right hand digit will be flashing to indicate that the Up and Down buttons can be used to change the value.

To be able to set timing and encoder count values (for pulse delay, pulse width and retrigger time) a scheme is used where the exponent (power of ten) of the value is set. For timings, the exponent values are as follows:

Exponent value	Multiplier	Number format	Range of values
E 0	1	999.	Values are displayed in seconds from 1s to 999s in steps of 1s.
E-1	0.1	99.9	Values are displayed in seconds from 0.1s to 99.9s in steps of 0.1s.
E-2	0.01	9.99	Values are displayed in seconds from 0.01s to 9.99s in steps of 0.01s.
E-3	0.001	999.	Values are displayed in milliseconds from 1ms to 999ms in steps of 1ms.
E-4	0.0001	99.9	Values are displayed in milliseconds from 0.1ms to 99.9ms in steps of 0.1ms.

The flow diagram for entering timings on the keypad is given below.

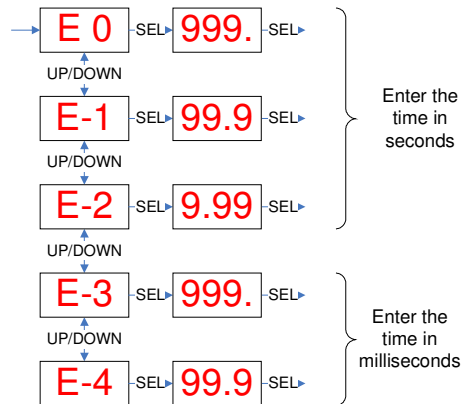

For encoder counts, the exponent values are as follows:

Exponent value	Multiplier	Number format	Range of values
E 0	1	999.	Values are from 1 count to 999 counts in steps of 1.
E 1	10	9.99	Values are displayed in K from 0.01K counts to 9.99K counts in steps of 0.01K.
E 2	100	99.9	Values are displayed in K (thousands) from 0.1K counts to 99.9K counts in steps of 0.1K.
E 3	1000	999.	Values are displayed in K from 1K counts to 999K counts in steps of 1K.
E 4	10000	9.99	Values are displayed in M (millions) from 0.01M counts to 9.99M counts in steps of 0.01M.
E 5	100000	99.9	Values are displayed in M from 0.1M counts to 99.9M counts in steps of 0.1M.
E 6	1000000	999.	Values are displayed in M from 1M counts to 999M counts in steps of 1M.

The flow diagram for entering encoder counts on the keypad is given below.

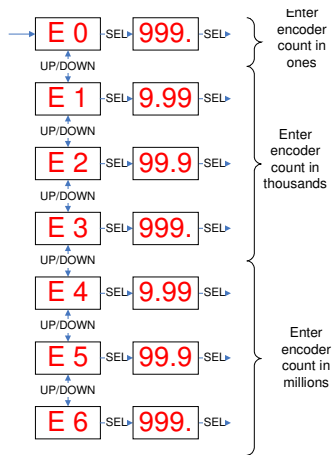

7.3.2 Setting Up Encoder Mode

Set the encoder mode from the keypad as follows. Press and hold the SEL button until the display shows “OP1”. Use the UP and DOWN buttons to select “Enc” then press SEL. Select the encoder mode using UP and DOWN and press SEL.

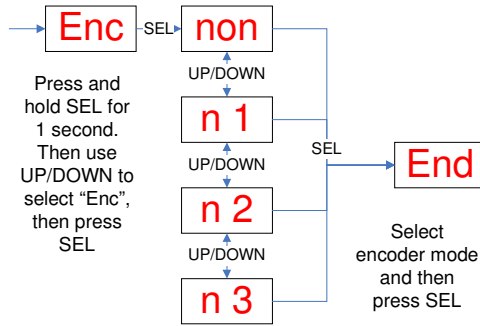

7.3.3 Setting Up The Free Running Timer

Set the free running timer period from the keypad as follows. Press and hold the SEL button until the display shows “OP1”. Use the UP and DOWN buttons to select “FrE” then press SEL. Set the free running timer period. See section 7.3.1 for a description of how to set the time period.

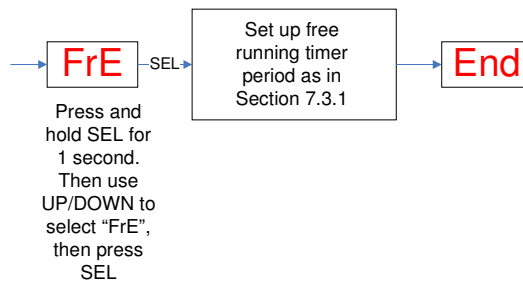

7.3.4 Setting Up An Output Channel

The overall structure for setting up an output channel is given below. Configuration mode must be entered once for each output channel to be set up.

The output mode names are given in Section 6. Depending on the selected mode, the user will be prompted to enter a time or a number of encoder pulses as appropriate for the pulse delay and pulse width.

The flag names are given in Section 6. A minus (“-”) sign indicates that the flag is not set. So “F-I” indicates that the I flag is not set and “F I” indicates that it is set.

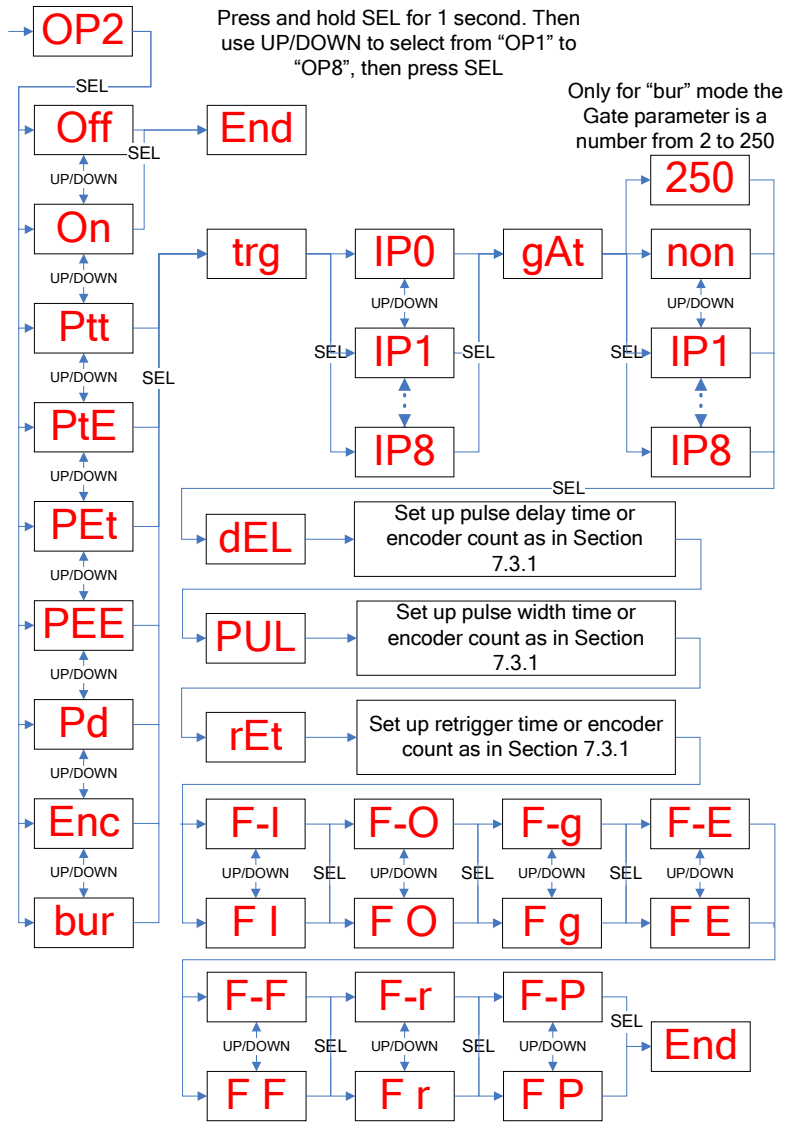

8 Ethernet Setup

You may need to ask your network administrator for advice about setting up the Ethernet connection.

Ethernet set up is not affected by cold booting the CC320.

8.1 Connection

The Ethernet link uses a 10 base-T connection on an RJ45 connector. The CC320 will usually be connected to a network switch (or hub or router). It is also possible to connect it direct into the network port on a PC by using a swapover cable.

8.2 MAC Address

The CC320 MAC address is:

0x00.0x0B.0x75.0x01.0xNN.0xNN.

8.3 IP Address

The CC320 needs an IP address to communicate over Ethernet. There are two ways to get an IP address; either a fixed address configured in the unit or using DHCP.

Most networks use a DHCP server. If there is a PC on the network, You may be able to find out whether a PC on the same network uses DCHP as follows:

- Go to Control Panel
- Select Network Connections
- Right click on Local Area Connection. Select Properties
- From the list, select Internet Protocol (TCP/IP), press Properties

If “Obtain an IP address automatically” is set, then DHCP is probably used. However, there may be an alternative fixed IP address on the “Alternative Configuration” tab.

You can find out what IP address is being used by a PC at any time by:

- Go to Control Panel
- Select Network Connections
- Right click on Local Area Connection. Select Status
- Select the Support tab. The IP address is displayed

When using a fixed IP address, you must ensure that you use an IP address that is not being used by any other device on the network. It is usual to keep the first three numbers of the IP address the same as other devices and to change only the last number. For example, if you have a network consisting of a PC (IP address 192.168.1.35) and two CC320s, you might give them addresses 192.168.1.201 and 192.168.1.202.

For DHCP mode, the CC320 acquires its IP address, subnet mask and gateway address from a DHCP server. Otherwise the CC320 has a fixed IP address, subnet mask and gateway address.

8.3.1 Setting DHCP or an IP Address from the Keypad

Set DHCP mode from the keypad as follows. Press and hold the SEL button until the display shows “OP1”. Use the UP and DOWN buttons to select “ETH” then press SEL. The display will either show “FIP” for a fixed IP address or “dhC” for DHCP. Use the UP and DOWN buttons to select “dhC” and press SEL.

For a fixed IP address, select “FIP” and press SEL. The user will be prompted to enter four bytes of the IP address, four bytes of the address submask and then four bytes of the gateway address.

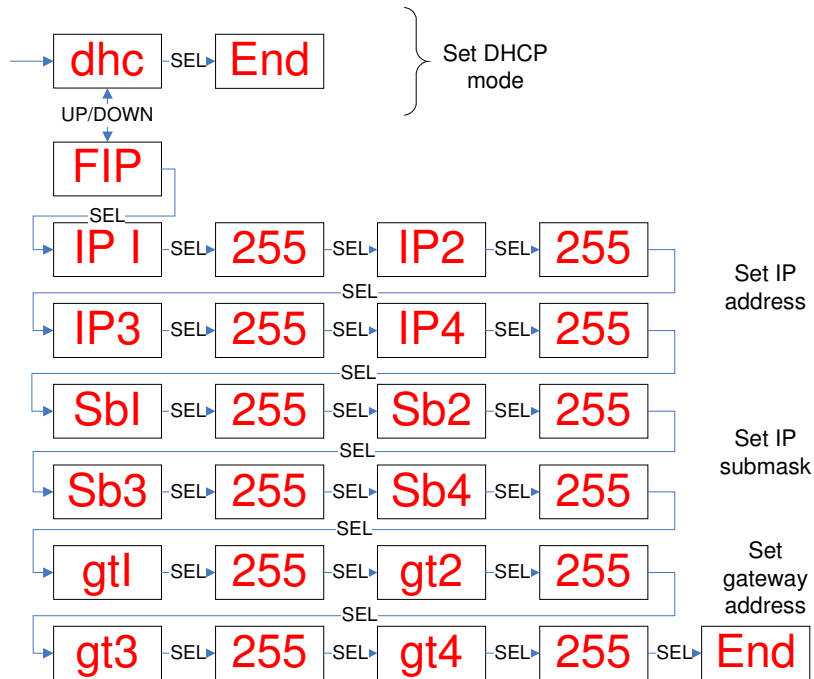

When an IP address has been assigned using DHCP, the address can be read from the keypad as follows. Press and hold the SEL button until the display shows “OP1”. Use the UP and DOWN buttons to select “ETH” then press SEL. Use the UP and DOWN buttons to select “rIP” and press SEL. Keep pressing SEL and read the four values of the IP address. The example below shows the IP address 192.168.1.71.

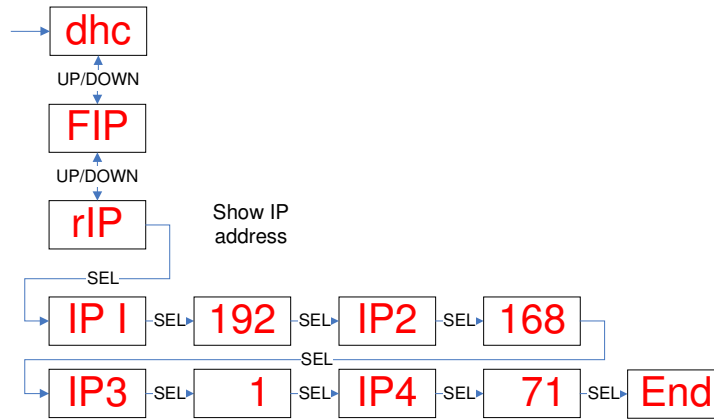

8.3.2 Setting DHCP or an IP Address from the Keypad

The DHCP mode or a Fixed IP address can be configured from the Ethernet Demo application which can be downloaded from the CC320 page at www.gardasoft.com.

Communication

All the features below are implemented in a demonstration program available from www.gardasoft.com.

8.3.3 Automatic Sensing

The CC320 will send out a message on three events:

- On power up
- When an IP address is received or renewed by DHCP
- When an enquiry message is received

On the first two events, the message is broadcast. On the third it is a reply to a single IP address.

An enquiry message is a UDP packet from source port 30310, destination port 30311 with the message body "Gardasoft Search" (8-bit ASCII, 13 characters).

The message output by the CC320 is a UDP packet from source port 30311, destination port 30310. It is formatted as:

```
Gardasoft,CC320,000000,111111111111,22222222
```

(8-bit ASCII, 44 characters), where

000000	the serial number of the unit
111111111111	the MAC address in 6 HEX bytes
22222222	the IP address in 4 HEX bytes

For example for CC320 serial number 12345, IP address 192.168.1.103, MAC address 00.0B.75.01.80.99 the packet will contain

```
Gardasoft,CC320,012345,000B75018099,C0A80167
```

9 Webpage Configuration

The CC320 has a small webserver inside, so that it can be configured from a standard web browser, such as Internet Explorer.

The IP address of the CC320 must be known (see the section on “Ethernet Setup.” Open a web browser window and type the IP address (for example 192.168.1.71) of the CC320 into the URL box at the top. The main page of the CC320 webserver should be shown.

9.1 Main Page

The main page shows general information about the CC320 and can be used to set up the Encoder mode and the Free Running Timer period. Press the Submit button to update the CC320 and save the changes to non-volatile memory.

Links are provided to the channel configuration pages.

9.2 Channel Configuration Pages

There is one Channel Configuration Page for each output channel. All the parameters for each output channel can be set up. Press the Submit button to update the CC320 and save the changes to non-volatile memory.

10 UDP and TCP/IP Configuration

10.1 Communication

The CC320 can be configured via the Ethernet connection using UDP or TCP/IP. A demonstration program with source code can be downloaded from www.gardasoft.com.

Communication consists of commands sent by the host (controlling PC). All output generated by the command is returned in reply UDP or TCP/IP packets. The last character sent is ">" ("greater than" symbol). Once this is received, the host knows that the command has been completed. It is recommended that the host waits for the ">" symbol before sending the next command. UDP communications are not guaranteed to arrive, so the host software must be able to cope with lost messages.

Using the GT command, a host can request that a message is sent to it whenever an error occurs.

For TCP, commands from a host should be sent to destination port 30313. Replies will be to destination port 30312. For UDP, commands from a host should be sent from source port 30312 to destination port 30313. Replies will be sent from source port 30313 to destination port 30312.

A TCP/IP connection will timeout and close if it is idle for more than 10 seconds. The host must send regular "heartbeat" commands (eg "VR") to keep the link open.

10.2 Command Structure

Several commands can be put into one command line by separating them by a semi-colon (;). A carriage return character should be sent to terminate the command line. The CC320 will send any replies to the commands and then send a '>' character to indicate that the command line has been completed.

Commands comprise a code of two letters followed by the parameters (if any) needed for the command. Spaces in the commands are ignored.

Numeric parameters are separated by a comma (,). For a parameter which is a time period the default units are milliseconds. "s", "ms" or "us" can be added to the end of the number to indicate seconds, milliseconds or microseconds. "K" can be used for 1000 encoder pulses and "M" for 1000000 encoder pulses. For example:

Parameter	Meaning
0.1	0.1 milliseconds
200us	200 microseconds
0.1s	0.1 seconds
100	100 encoder pulses
15.5K	15500 encoder pulses
14.5M	14500000 encoder pulses

Encoder values can be up to 1,000,000,000. Time periods can be from 0.1ms to 100 seconds in steps of 0.1ms.

Note that parameters are in “USA/UK” format so that one half is written “0.5” not “0,5”

The command codes and their meaning are described below. The single upper case letter codes for the parameters are also shown, followed by lower case letters denoting the numeric argument.

Error number	Reason
Err 1	A parameter value is invalid
Err 2	Command not recognised
Err 3	Numeric value is wrong format
Err 4	Wrong number of parameters
Err 17	Can't save settings to EEPROM

Any changes made using Ethernet commands are not saved permanently until the AW command has been issued.

10.3 Commands

Show the firmware version

VR

Outputs the version number of the firmware, for example “001”.

Clear Configuration

CL

Clears the configuration to the cold boot state.

Save Configuration

AW

Saves the configuration to non-volatile memory. When the CC320 is turned off and on this configuration will be restored.

Show Configuration

ST

The current configuration is shown. The first line gives the encoder mode and the internal trigger timing. Then the configuration of each of the outputs is given, one per line. The flags are shown as lower case letters if not set and upper case if set. Example output from this command is:

```
No encoder, trigger period = 1.000s
OP1: MD=2, IP=1, GT=-, DL=100.00ms, PL=100.00ms, RT= 0.00ms, iogefrp
OP2: MD=2, IP=2, GT=-, DL=100.00ms, PL=100.00ms, RT= 0.00ms, iogefrp
OP3: MD=2, IP=3, GT=-, DL=100.00ms, PL=100.00ms, RT= 0.00ms, iogefrp
OP4: MD=2, IP=4, GT=-, DL=100.00ms, PL=100.00ms, RT= 0.00ms, iogefrp
OP5: MD=2, IP=5, GT=-, DL=100.00ms, PL=100.00ms, RT= 0.00ms, iogefrp
```

OP6: MD=2, IP=0, GT=-, DL=100.00ms, PL=100.00ms, RT= 0.00ms, iogefrp
 OP7: MD=2, IP=0, GT=-, DL=200.00ms, PL=100.00ms, RT= 0.00ms, iogefrp
 OP8: MD=2, IP=0, GT=-, DL=300.00ms, PL=100.00ms, RT= 0.00ms, iogefrp

Enable Ethernet Messages

GTm

m = 0 to disable Ethernet messages
 = 1 to enable Ethernet messages

When Ethernet messages are enabled, any trigger tag messages and error reports are sent to the most recent UDP or TCP address from which a command has been received.

Read any error messages

GR

If Ethernet messages are not enabled, the last error number can be read by this command. The reply is of the form:

Err 45 Error 45 was the last error
 Err 0 No error has occurred since the last GR command

Set Pass/Fail

SNc,t,p

c which output channel (1 to 8)
 t the trigger tag number
 p 1 = pass, 0 = fail

For Resync mode, this command returned the pass/fail state of image processing for the given trigger tag.

For example:

SN3,76,1 Output 3, trigger tag 76 is a pass

Set the output mode

RSc,m,i,g,f

c which output channel (1 to 8)
 m mode
 i which trigger input (0 for free running timer, or 1 to 8)
 g which gate input (0 for none, or 1 to 8)
 f flags

Sets the configuration for an output channel. See section 6 for a description of these parameters.

For example:

RS4,3,5,0,2

will set output channel 4 to be pulse mode (Pft), triggered by input 5, no gate input and flags = 2 (invert the output). The flags parameter must be entered as a decimal number.

Set the output pulse timing

RTc,p,d

c which output channel (1 to 8)
 p Pulse width (time or encoder pulses)
 d Pulse delay (time or encoder pulses)

The pulse delay and pulse width timings are set. These timings will either be a time period or a number of encoder pulses, as previously set by the mode parameter of the RS command.

The mode should be set with the RS command before the pulse timing is set.

For example:

RT2,3ms,5K Output 2, 3ms output pulse after 5000 encoder pulses

Set retrigger time

RRc,r

c which output channel (1 to 8)

r Retrigger time or encoder pulses

The retrigger time is the minimum time from when an output is triggered to the next time. The mode should be set before the retrigger time.

For example:

RR4,10ms Output 4 won't accept another trigger until 10ms after the previous one

Set the internal free running timer

RB1,p

p Period of timer

The internal timer is set to run at the specified time period. For example:

RB1,1ms Set period to 1ms (1000Hz)

RB1,3s Set period to 3s (once per 3 seconds)

RB1,40 Set period to 40ms (25Hz)

If the period is zero, then the internal timer is turned off.

Set encoder mode

REe

REe,n,p

e = 0 to turn encoder off

 = 1 for a one-wire encoder

 = 2 for a two-wire encoder

 = 3 for a three-wire encoder

n Number of encoder pulses per revolution.

p Options (to be defined)

Sets the encoder type. The number of pulses per revolution is only relevant for a 3-wire encoder.

Set an output

RVc,v

c which output channel (1 to 8)

v = 0 to set the output to a logic 0 (logic 1 if O flag is set)

 = 1 to set the output to a logic 1 (logic 0 if O flag is set)

Sets an output to a given logic level. This is a temporary override which will be cancelled the next time the output is pulsed or if its configuration is changed.

If the "O" configuration flag is set for an output the the output will be inverted.

Show the state of an input.

Rli

i which input channel (1 to 8)

Replies “VL0” if the input is logic 0 and “VL1” if the input is on.

Show the state of an output

ROc

c which output channel (1 to 8)

Replies “VL0” if the output is logic 0 and “VL1” if the output is on.

Simulate an Input Pulse

MPi

c which input channel (0 to 8)

Generates a simulated pulse on an input. The input can be a physical input or the free running timer (IPO).

Disable Keyboard

KBd

d = 0 Enable keyboard

d = 1 Disable keyboard

In some applications it may be necessary to disable the keyboard so that operation can only be controlled from the Ethernet port. The setting of this command is restored after a power cycle.

10.4 Command Summary

Function	Command Syntax
Show the firmware version	VR
Clear all configuration	CL
Show configuration	ST
Make configuration non-volatile	AW
Read any error messages	GR
Enable Ethernet messages	GTm
Set pass/fail	SNC,t,p
Set pulse timing	RTc,p,d RTc,p,d,r
Set retrigger time	RRc,r
Set output mode	RSc,m,i,g,f
Set internal trigger period	RB1,p
Set encoder mode	REe REe,n,p
Sets an output	RVc,v
Read state of an input	Rli
Read state of an output	ROc
Simulate an input pulse	MPi
Disable keyboard	KBd

A. Timing

The following timings apply for CC320 V002. All these timing assume that a single output channel is being used. Simultaneous events on multiple inputs can cause some variation. Typically this can vary the timing by up to 100us.

Pulse widths below 3ms are repeatable to within 1us and are not subject to variation even with other simultaneous events. Pulse widths above 3ms are repeatable to within 100us and are subject to variation.

Pulse delays are repeatable to within 100us.

The execution time of a simple Ethernet command (for example the GT command) is around 15ms.

The maximum frequency for a one-wire encoder is around 700KHz.

In buffer mode there is a delay of 20us between the input changing and the output changing.

B. Error Codes

Error codes may be displayed by the CC320 or returned as a reply to an Ethernet message. These are shown as “Errn”, where nn gives the number of the error. To cancel the error message, press “SEL”.

EEPROM is the non-volatile memory used to save the configuration and Ethernet settings. If the EEPROM errors occur repeatedly, then the controller may need to be returned for repair.

The error codes are:

Error number	Reason
Err 1	Ethernet command: A parameter value is invalid
Err 2	Ethernet command: Command not recognised
Err 3	Ethernet command: Numeric value is wrong format
Err 4	Ethernet command: Wrong number of parameters
Err 5	Can't read EEPROM.
Err 6, 16	EEPROM corrupt. The configuration has been cleared.
Err 8, 17, 25	Can't save settings to EEPROM
Err 27	Can't read Ethernet settings from EEPROM, so these may be incorrect.
Err 28	Can't save Ethernet settings to EEPROM.

Gardasoft LED Lighting Controllers

The following products are available at the time of writing. New products will be introduced. See www.gardasoft.com for details of the current range.

PP500 Range

- 2 output channels up to 10A each
- 2 digital inputs
- Front panel configuration

PP500 Lighting controller

PP520 Lighting controller with Ethernet control

PP701 DIN Rail mounting clip for PP500 and PP500F ranges

PP500F Range

- Same as the PP500 range but with fast pulsing
- Pulse delay from 10 μ s to 9.9ms in 1 μ s steps
- Pulse width from 1 μ s to 9.9ms in 1 μ s steps

PP500F Lighting controller

PP520F Lighting controller with Ethernet control

PP860, PP861

- High current, high accuracy controller
- 8 output channels up to 20A each
- Pulses repeatable to 0.1 microseconds
- RS232 configuration

Machine Vision Timing Controller

CC320 Controller

- 8 digital inputs
- 8 digital outputs
- 1, 2, or 3 wire Encoder input
- Very flexible operation
- Ethernet control
- Front panel configuration

PP703 DIN Rail mounting clip for CC320